

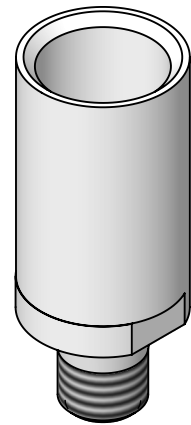

This drawing is the property of MELTRIC Corporation, Franklin (Milwaukee) Wisconsin, USA. Any unauthorized copying of this drawing by any means, ENG/RD/06 REV: 20 ISSUED DATE: 1/15/11 or disclosure of its contents to any person not authorized by MELTRIC Corporation or its agents to receive it, is strictly prohibited.

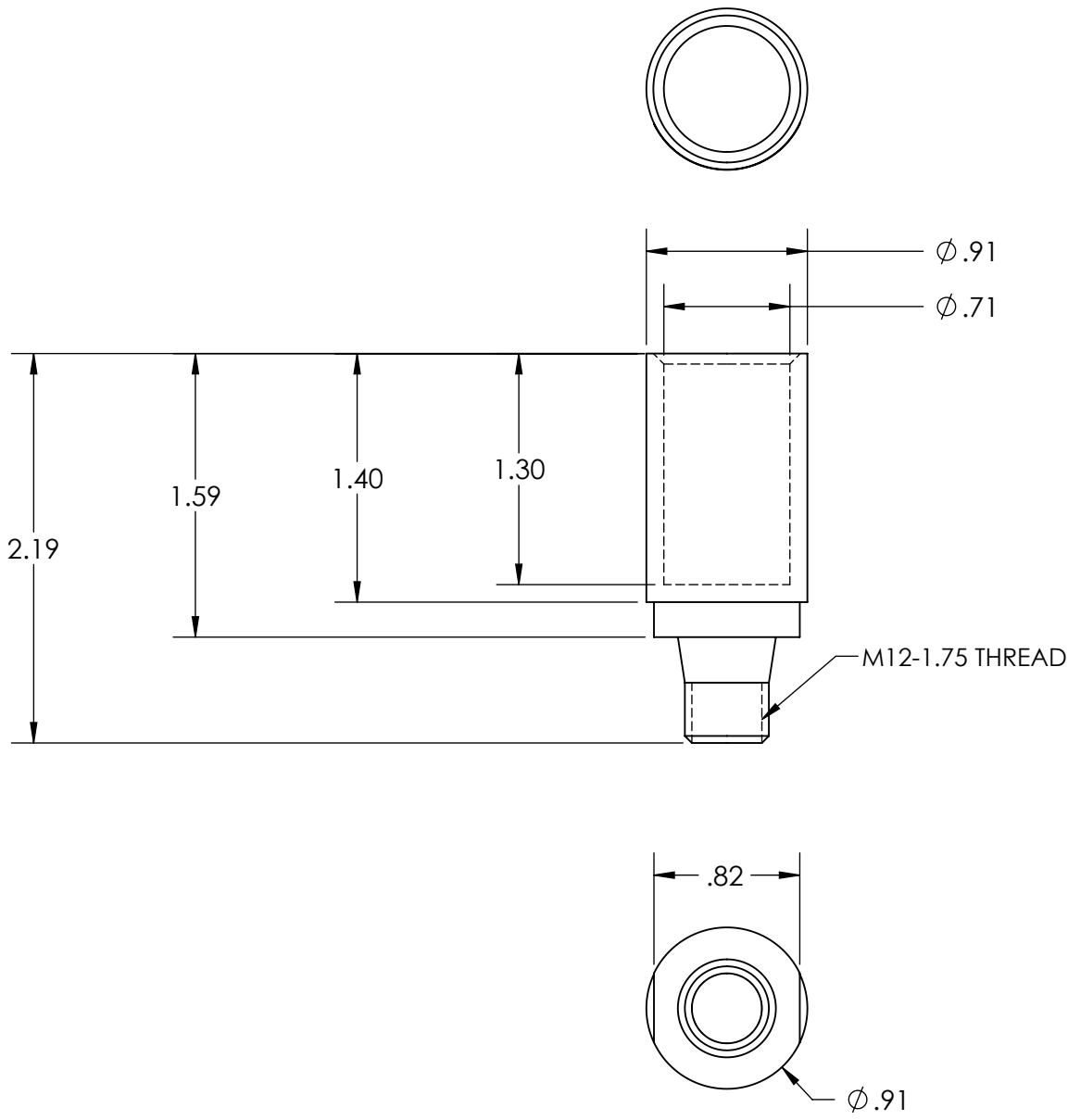

|  |  |
|--|--|
| TOLERANCES UNLESS OTHERWISE SPECIFIED  |  |
| MACHINED SURFACES $\sqrt[125]{\text{MAX}}$   | ENGLISH<br>0.X ±0.05<br>0.XX ±0.01<br>0.XXX ±0.005 |
| GROUND SURFACES $\sqrt[32]{\text{MAX}}$  |  |
| ANGLE TOLERANCE ±1°  |  |
| REMOVE BURRS & SHARP EDGES TO .015 MAX.  |  |
|  DIMENSIONS SHOWN IN OVALS ARE INSPECTION DIMENSIONS. |  |

|   |             |                                      |          |
|---|-------------|--------------------------------------|----------|
|  |             | DRAWING TITLE:                       |          |
| DRAWN   | APPROVED    | SP STRAIGHT FERRULE FOR 300MCM CABLE |          |
| DATE:   | SCALE       | MATERIAL:                            |          |
|   | NTS         | METAL                                |          |
| SHEET:  | PART NUMBER |                                      | REVISION |
| 1 OF 1  | 45-4A15D    |                                      |          |